

## 進階零組件工程圖與 CSWP 認證實務班

<附件一> 訓後成果示範圖，謹做為本課程之參考

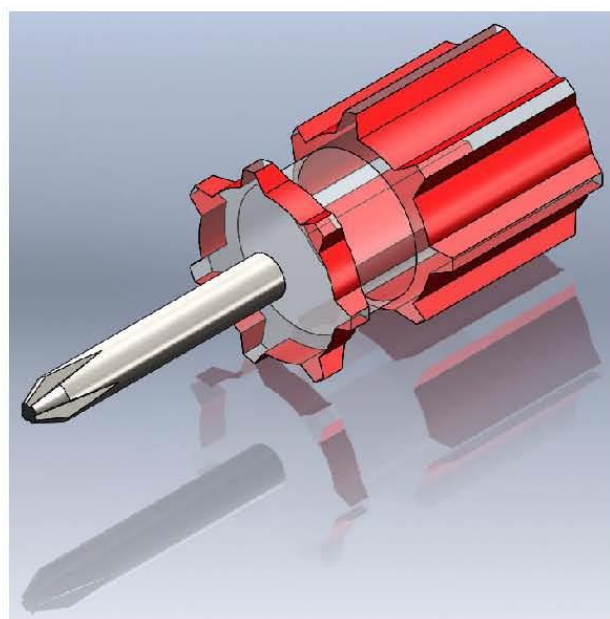

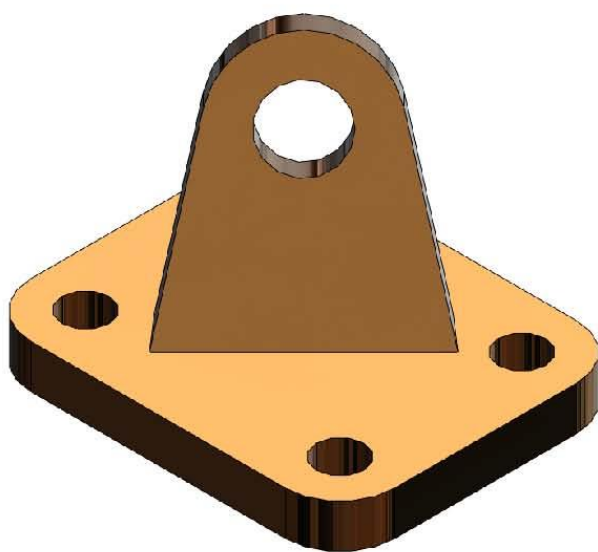

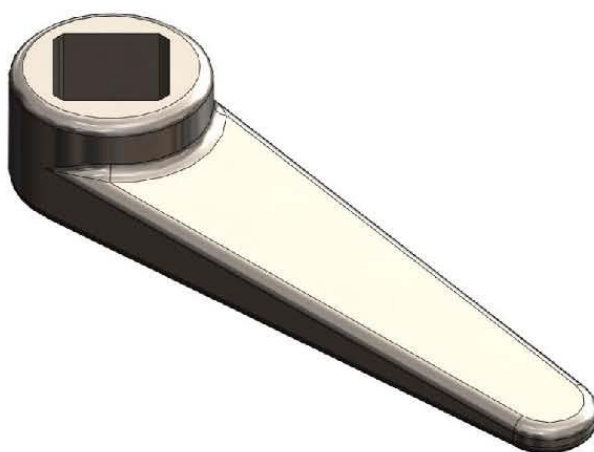
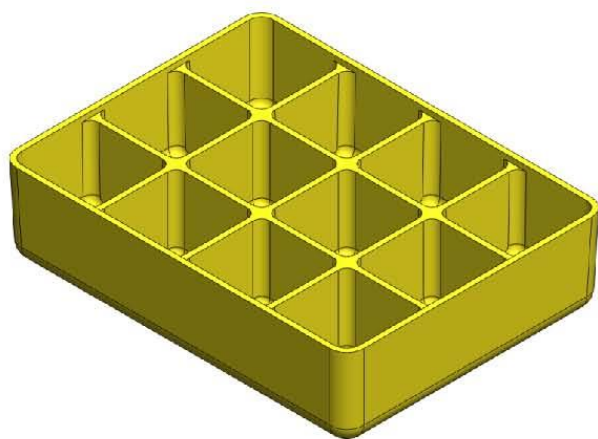
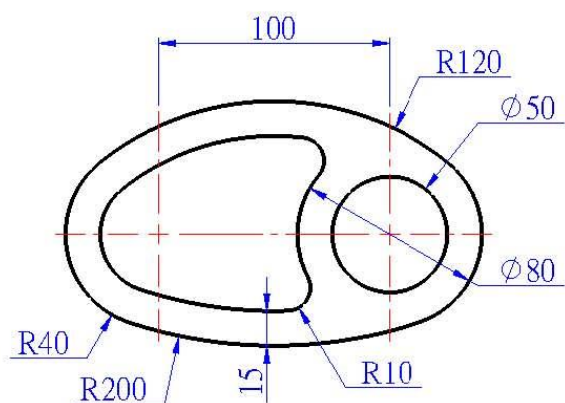
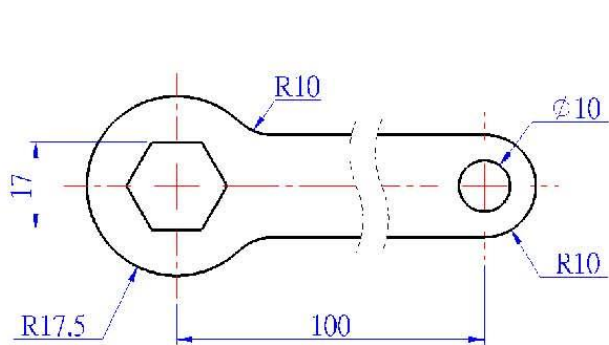
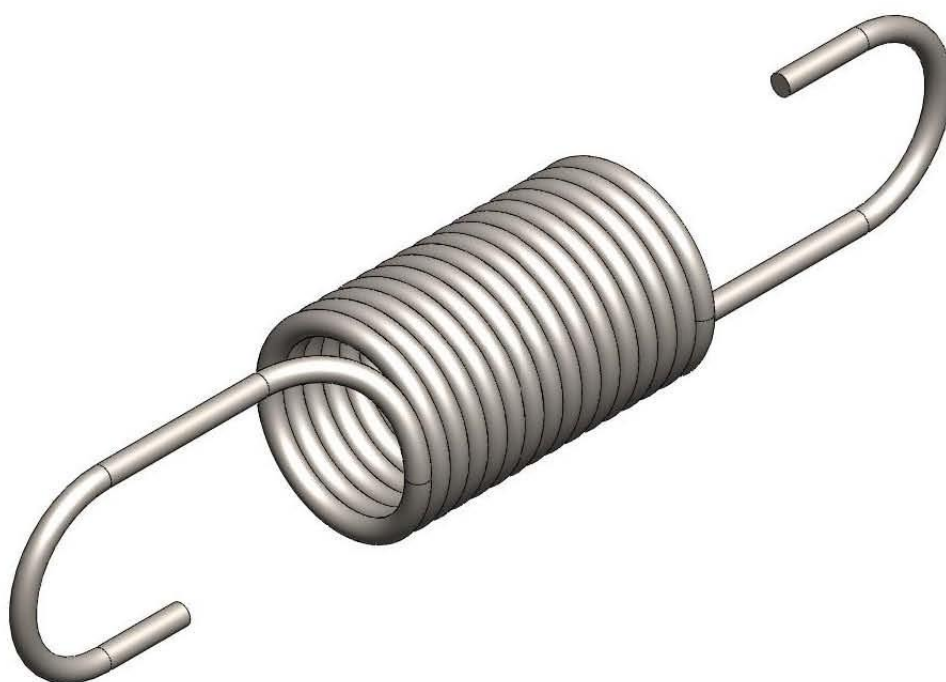
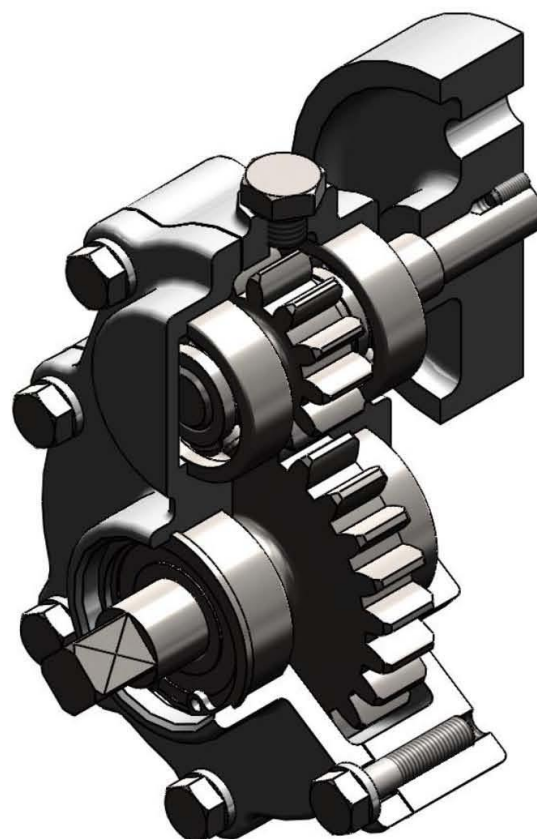
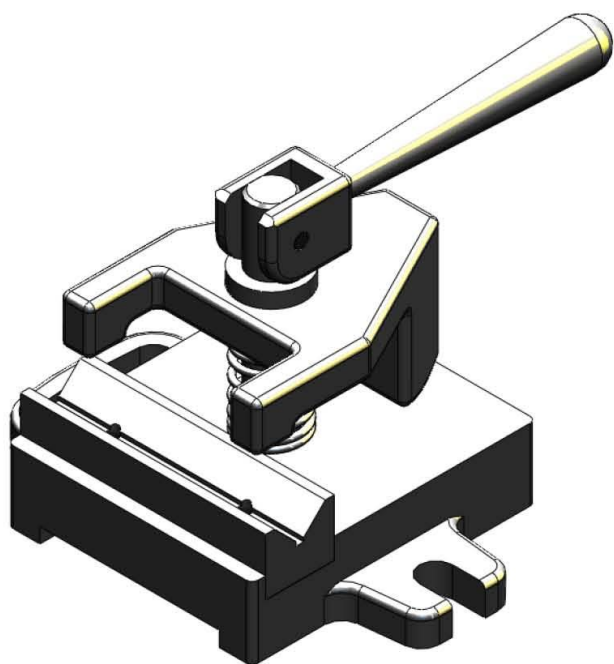
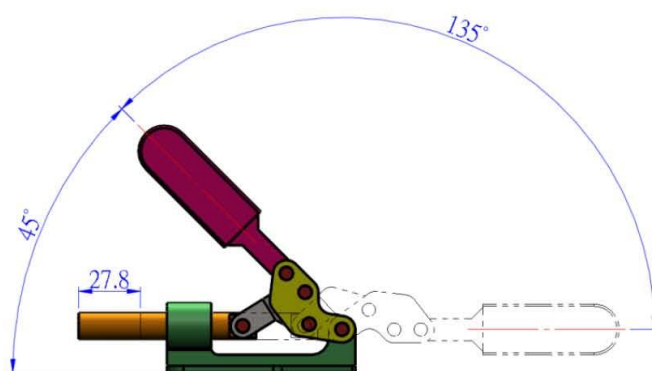
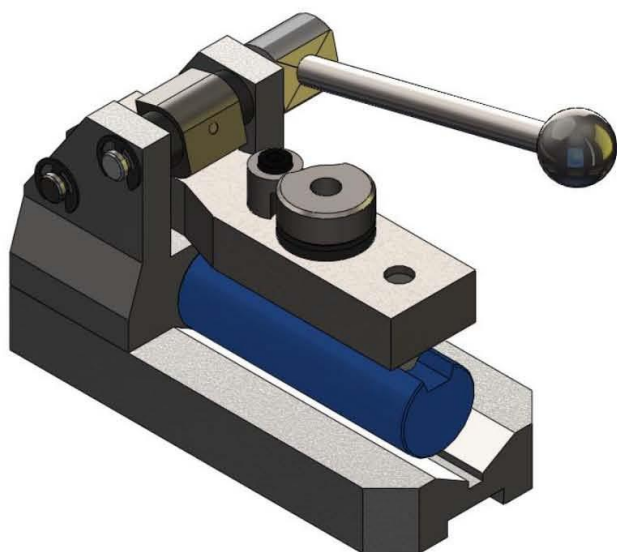
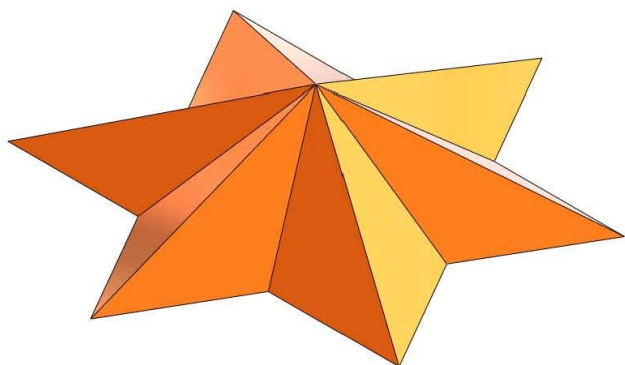

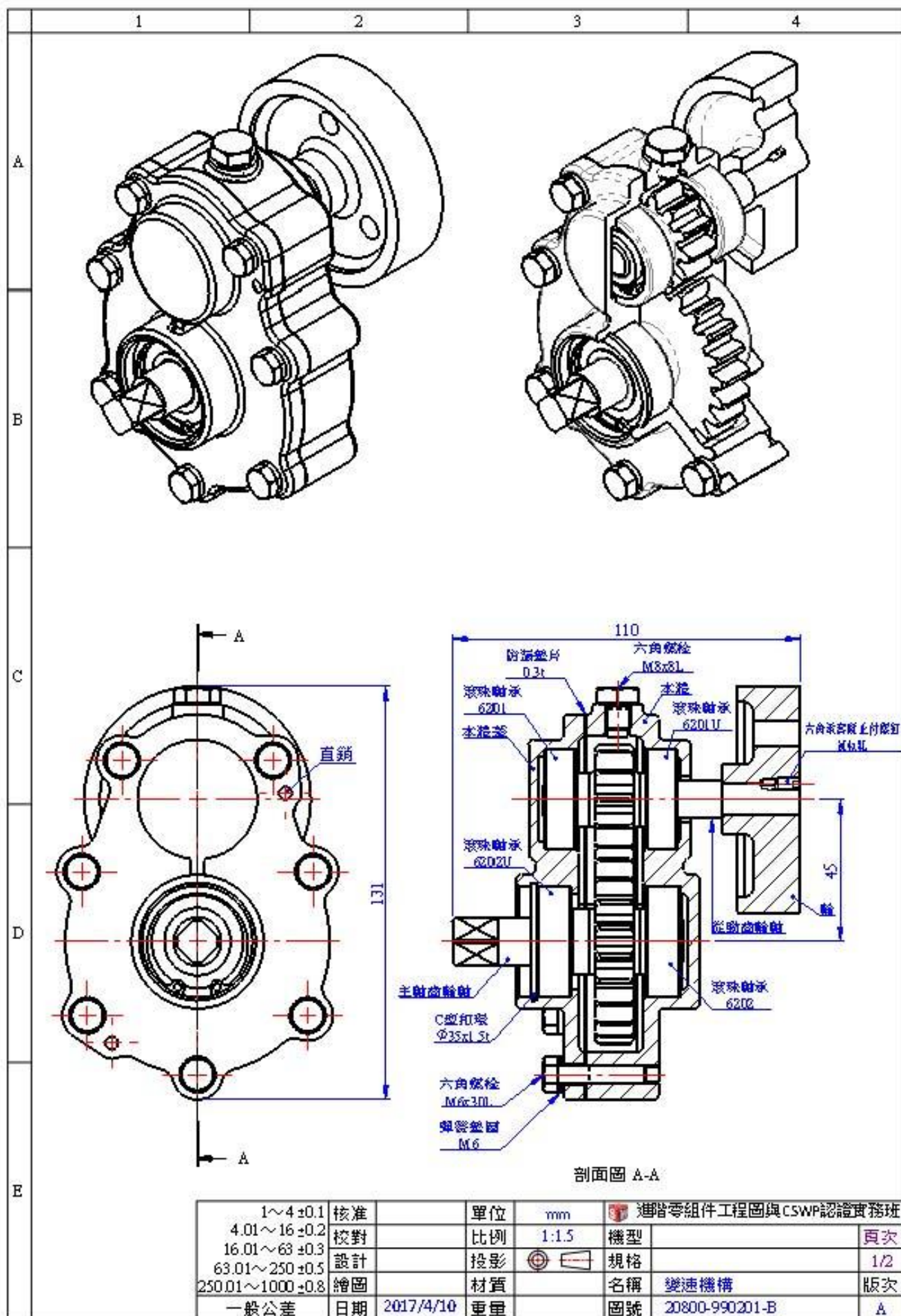

1~4 ±0.1	核准	單位	mm	進階零組件工程圖與CSWP認證實務班
4.01~16 ±0.2	校對	比例	1:1.5	機型
16.01~63 ±0.3	設計	投影		規格
63.01~250 ±0.5	繪圖	材質		名稱 變速機構
250.01~1000 ±0.8	日期	重量		圖號 20800-990201-B
一般公差	日期	2017/4/10		頁次 A



1					2					3					4					5				
編號	名稱	材質	規格	版次	數量	編號	名稱	材質	規格	版次	數量	編號	名稱	材質	規格	版次	數量	編號	名稱	材質	規格	版次	數量	
1	本體	FC200		A	1	11	C型扣環	SUP3	∅35x1.5t	A	1	12	直銷	S50C	∅4x30L	A	2	13	六角螺絲	S20C	M8x8L	A	1	
2	本體蓋	FC200		A	1	14	六角螺絲	S20C	M6x30L	A	7	15	彈簧墊圈	SUP3	M6	A	7	16	六角承窩頭止付螺釘	S20C	M4x8L	A	1	
3	主軸齒輪軸	S45C		A	1																			
4	從動齒輪軸	S45C		A	1																			
5	輪	FC200		A	1																			
6	防漏墊片	硬橡膠	0.3t	A	1																			
7	滾珠軸承	-	6201U	A	1																			
8	滾珠軸承	-	6202	A	1																			
9	滾珠軸承	-	6201	A	1																			
10	滾珠軸承	-	6202U	A	1																			

1~4 ±0.1	核准	單位	mm	進階零組件工程圖與CSWP認證實務班
4.01~16 ±0.2	校對	比例	1:2.5	機型
16.01~63 ±0.3	設計	投影		規格
63.01~250 ±0.5	繪圖	材質		名稱
250.01~1000 ±0.8	一般公差	日期	2017/4/10	重量
		圖號	20800-990201-B	版次
				A

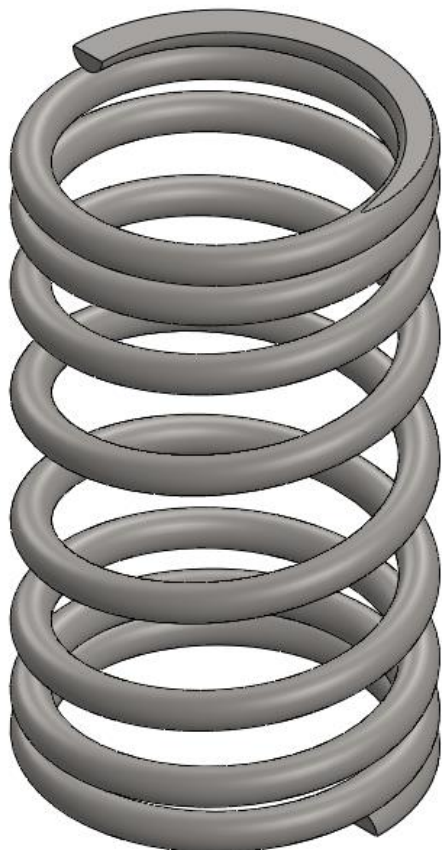

**\*參考文獻**

本教材之編撰曾參考下列書籍，謹向原著者致謝。

- 1、SolidWorks 寫真輯
- 2、電腦輔助設計製圖乙級術科實作秘笈
- 3、TQC+SolidWorks 2010 實體零件設計認證指南
- 4、台灣三住產品型錄技術資料

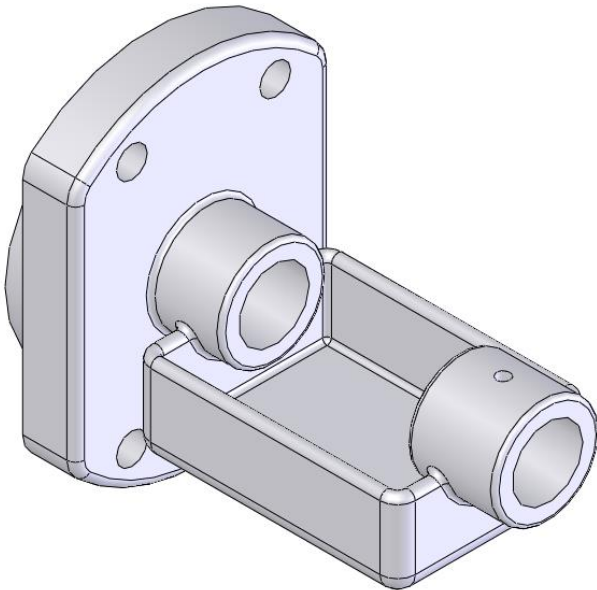
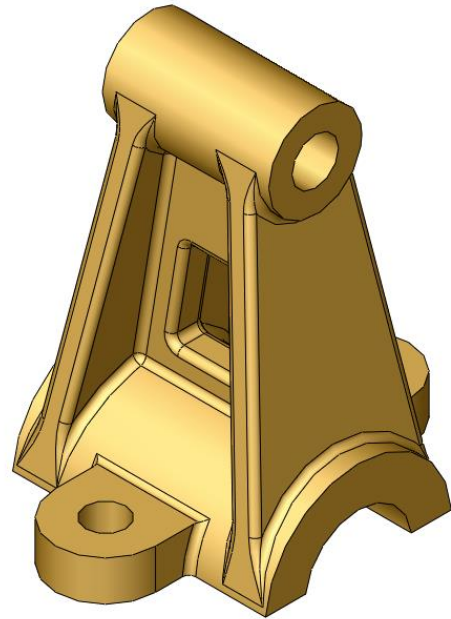
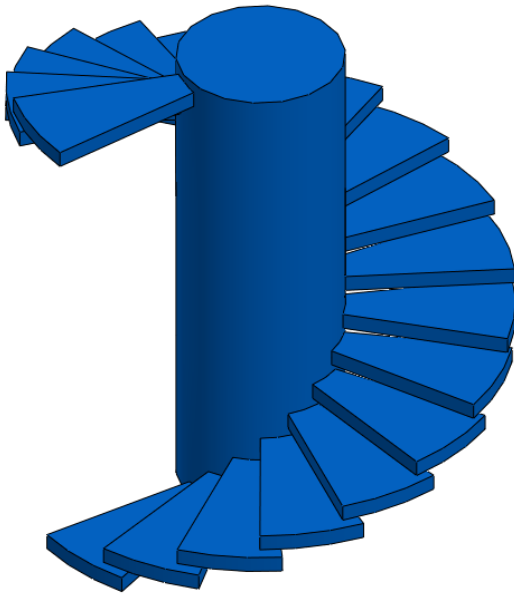
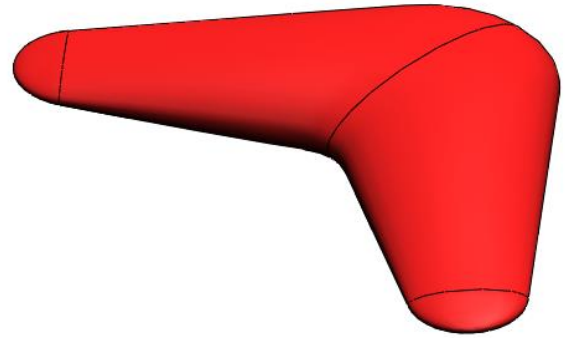
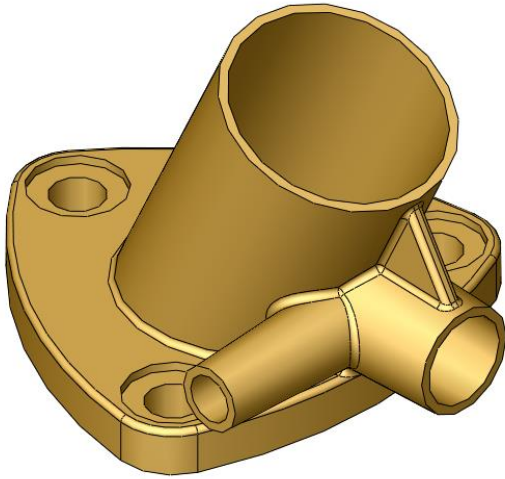

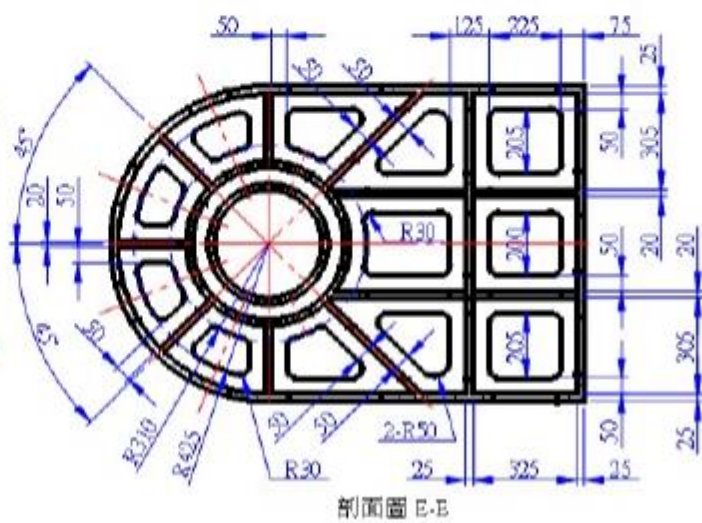
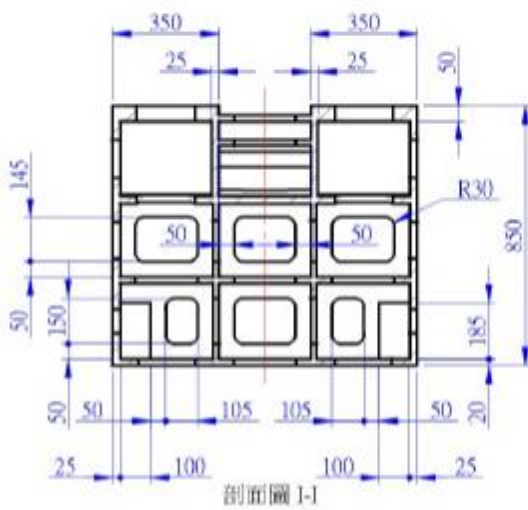
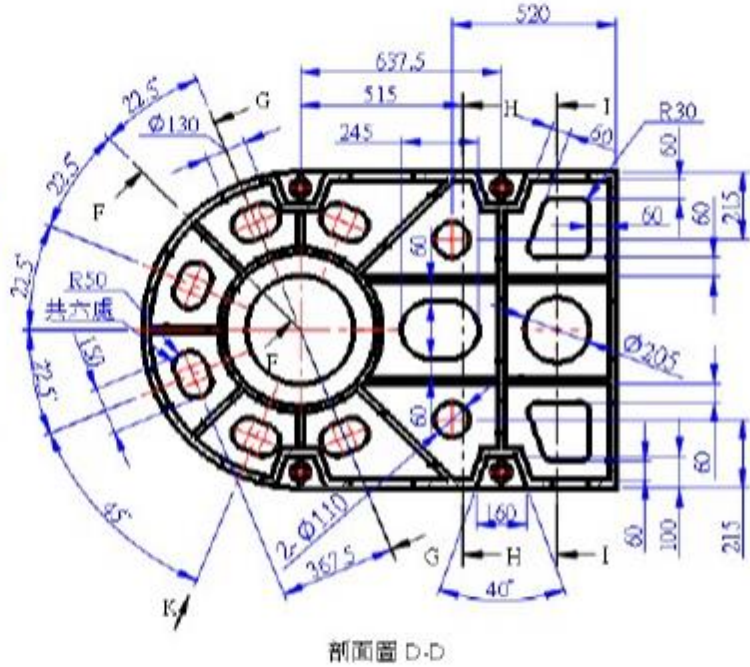
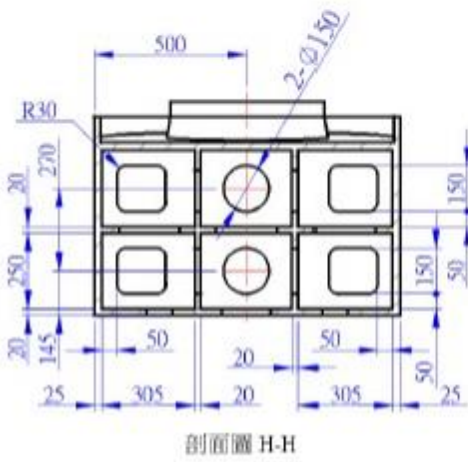
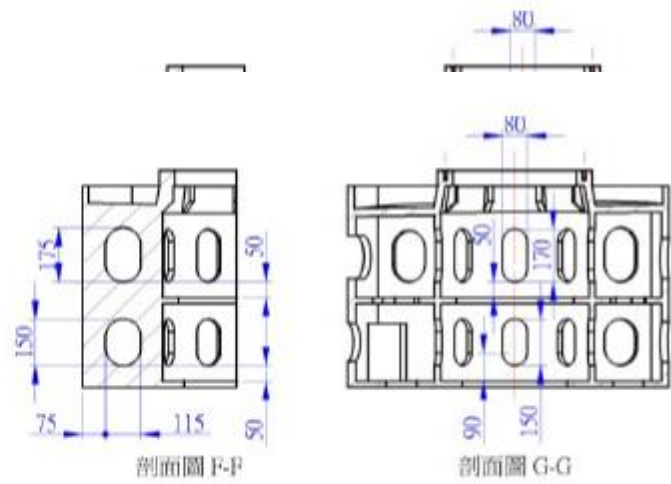
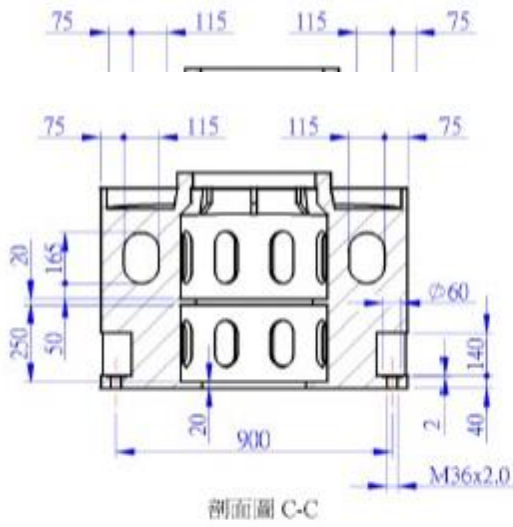

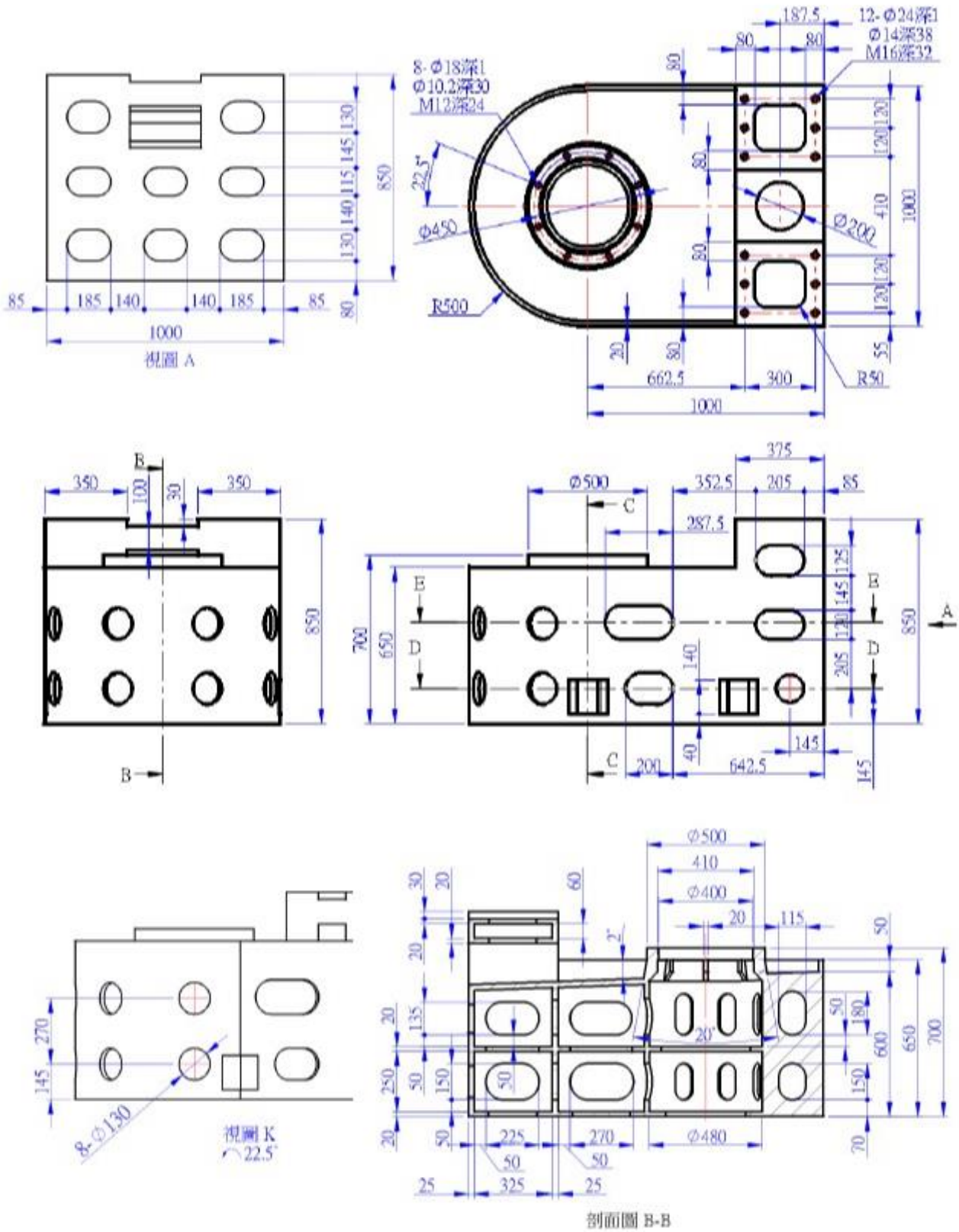



10、

